

Simplicity

is Simply Better



Multichopper

Construction, Drive and Assembly

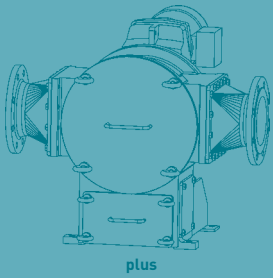

plus

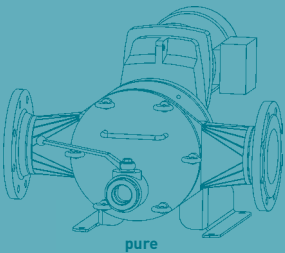
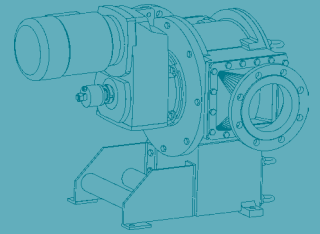
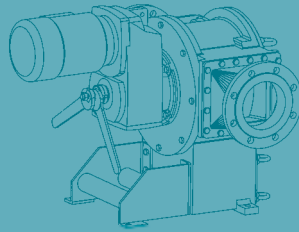

pure

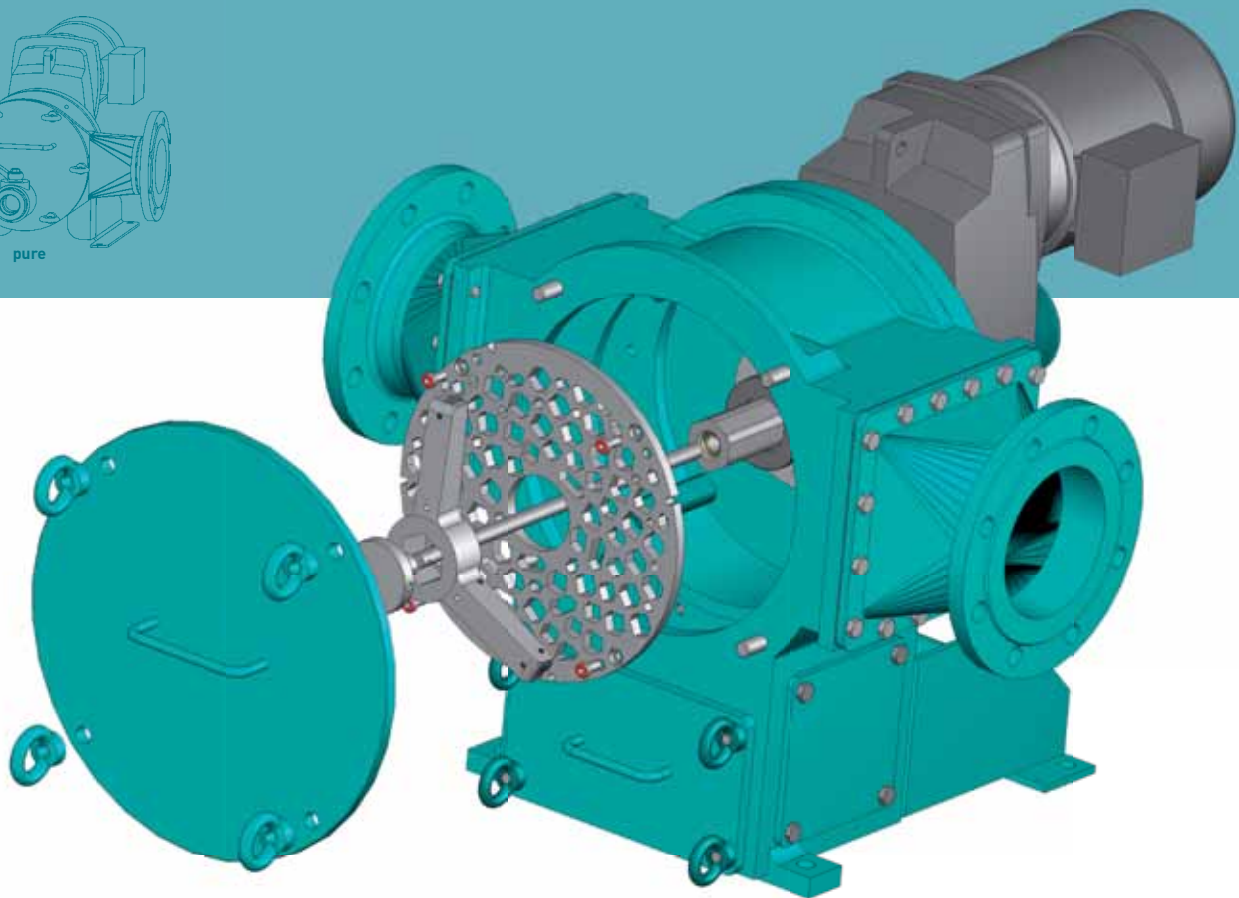

The Börger Multichopper incorporates advantageous technical and operational design features. Knife tension to the cutting plate (perforated disc) is adjustable from outside the unit. A central shaft clamp construction maintains the axially fixed blade alignment and tension to the reversible cutting plate. The shaft seal is supplied with the proven Börger mechanical seal with quench and

control. The Multichopper incorporates Börger's well-known maintenance friendly design. All rotating parts can be accessed, maintained or replaced via the removable front access cover, fitted with an eyebolt clamped construction. With no requirement for special tools. The Börger Multichopper is available in two designs. The Multichopper plus is equipped with a debris collector for solids

which cannot be macerated, while the Multichopper pure is designed to have no cavities in which the medium can become entrapped. Hence the Multichopper pure is built without a debris collector. The Multichopper is available in grey cast iron and stainless steel designs.

The Multichopper – designed for simple and effective operation.

MCA = Mechanical Cut Adjustment

Automatic adjusting device ensures constant optimized cut performance

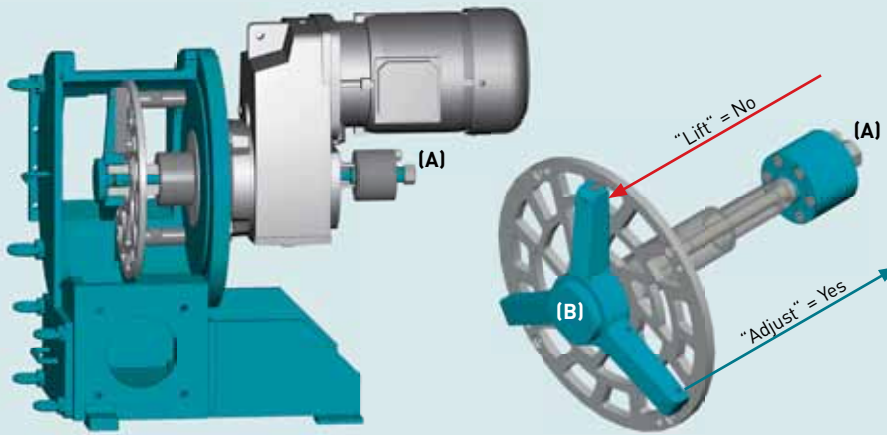

The **MCA** unit is an adjustment unit which works automatically. The rotating MCA cylinder **(A)**, attached externally, works with a constant cutting load and pulls the blades onto the cutting plate with the minimum force necessary. Only a small amount of load is used so that the cutting blades are only lightly held against the cutting plate in the working position with low stress.

When a clearance between the blades and cutting plates develops, the axial traction ensures that the cutting interplay between the blades and the cutting plate is always ideally set, guaranteeing that the Multichopper has an optimal cutting effect. The cutting preload is set completely independently. This technology is absolutely maintenance-free.

At a glance:

- The MCA unit is fitted externally, axial to the knife unit **(B)**.
- The MCA technology uses a clamp axle to hold the blades against the cutting plate with minimal preloading.
- The MCA unit only allows one direction of movement. The blades cannot be lifted from the cutting plate.
- The knife unit, clamp axle and MCA form a patented unit which rotates as one.

Intelligent technology in the adjustment cylinder **(MCA)** prevents the blades from lifting and resetting. The adjustment unit is located externally. The entire internal macerating space of the Multichopper is not restricted by any adjustment devices. Here, the entire space is available for the medium to be chopped.

Multichopper plus – in grey cast iron or stainless steel design, with large-volume debris collector

Multichopper pure – in stainless steel design, without debris collector, ensuring no deposits

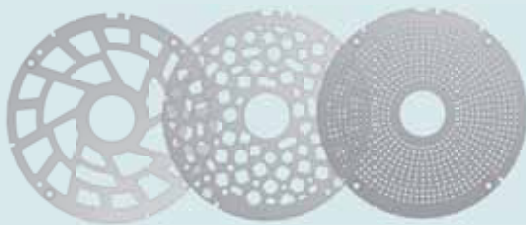

Börger has razor sharp solutions!

Single shaft grinder with central cutting plate and effective blades for solids reduction in liquid phases. The chopping result is mainly determined by the design of the cutting plate, the operating speed and the fluid velocity through the unit.



Direction of flow

The direction of flow can be determined onsite due to reversible flange connections (Multichopper plus) or by rotating the casing by 180° (Multichopper pure).

Unique in the world and exclusive from Börger:
Börger Multichopper MIP-Design allows the quick and convenient maintenance or replacement of all wetted parts, without removal of pipes, drives or other components. By your own staff.
Quick – Uncomplicated – Inexpensive



BOERGER, LCC

2860 Water Tower Place
Chanhasen, MN 55317
USA

Toll Free 877-726-3743

Phone 612-435-7300

Fax 612-435-7301

america@boerger.com

www.boerger.com



Spent vegetable oils and deep-frying fats are reconditioned in a Biodiesel Plant. The Multichopper reduces large solids to enable them to be separated easily in the downstream processes. The cleaned oils and fats are pumped to large Diesel-Engines driving generators for energy production. The Multichopper is handling a range of 400 usgpm with a maximum temperature of 140 °F.



The Multichopper pure is used to macerate vegetable solids in the manufacture of flavourings, oils and cosmetic ingredients. Within this process, the Multichopper pure chop the raw material pieces, which have already been roughly macerated and enriched with water, more finely. The crucial elements are the stainless steel design and that no pieces become stuck during macerating.



Food and garden waste are delivered to a biogas plant and are mixed with liquid. The Börger Multichopper and a Börger Multicrusher are installed to chop the solids and homogenize the product. Börger pumps transport the mass to an anaerobic digester. With the combination of the both Börger chopping machines the required solids size necessary for biogas plants are achieved.



In a municipal sewage treatment plant the wastewater is filtered by use of membrane technology. The membranes separate the sewage into permeate (filtered water) and sludge. The sludge is temporarily stored in large tanks. A sludge loading station equipped with a Börger Multichopper and a Rotary Lobe Pump will fill up tankers in minimal time for transfer to a dewatering station. The Multichopper protects the pump and the downstream dewatering equipment by reducing the solids size.